



Protecting Product Design

U.S. Design Patents

Presented by:
Michael Bertelson

Available For:

- “new, original and ornamental design for an article of manufacture”
(35 USC §171)
 - entire article
 - portion of article
 - surface ornamentation

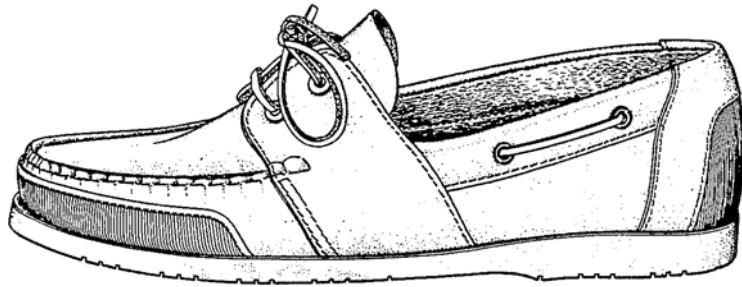

U.S. Design Patent No. 300,180

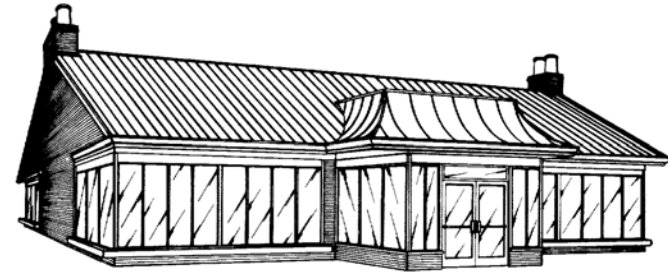

U.S. Design Pat. No. 269,550

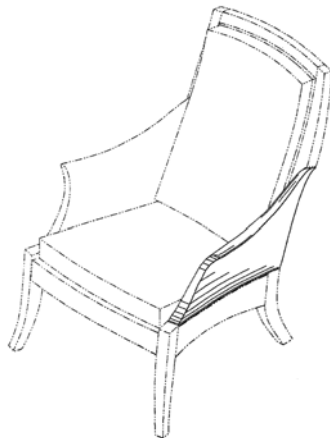

U.S. Design Patent No. 506,092

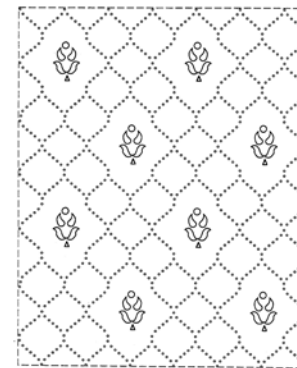

U.S. Design Patent No. 352,833

Also Articles of Manufacture:

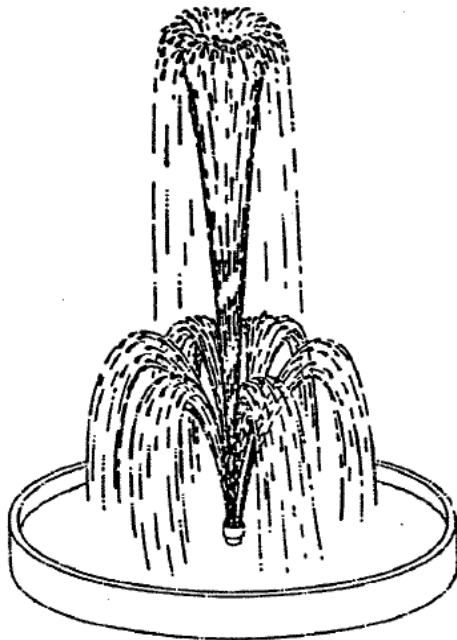

In re Hurby, 153 USPQ 61 (CCPA 1967)

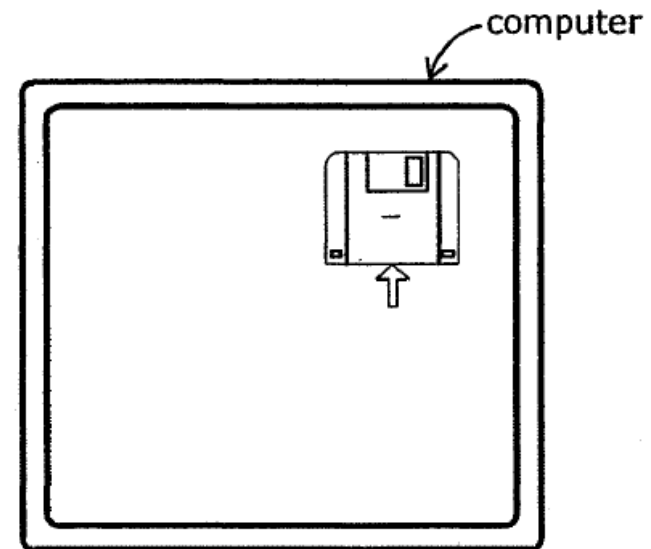

Manual for Patent Examining Procedure
1504.01(a)

Not Available For:

- purely “functional” designs

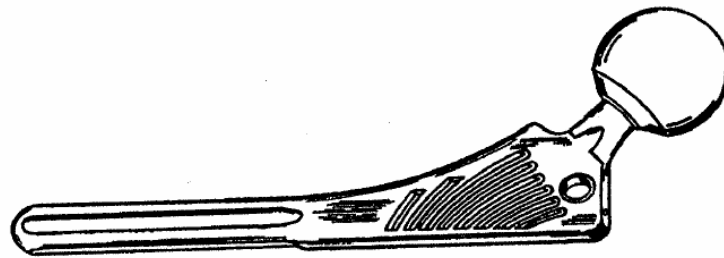

- design “concepts”



The Design Patent Application:

- Very Short Written Description
 - Title
 - Brief Description of Drawings
 - Claim
- Drawings
 - Key Part of a Design Patent
 - Most Expensive & Problematic

Drawings

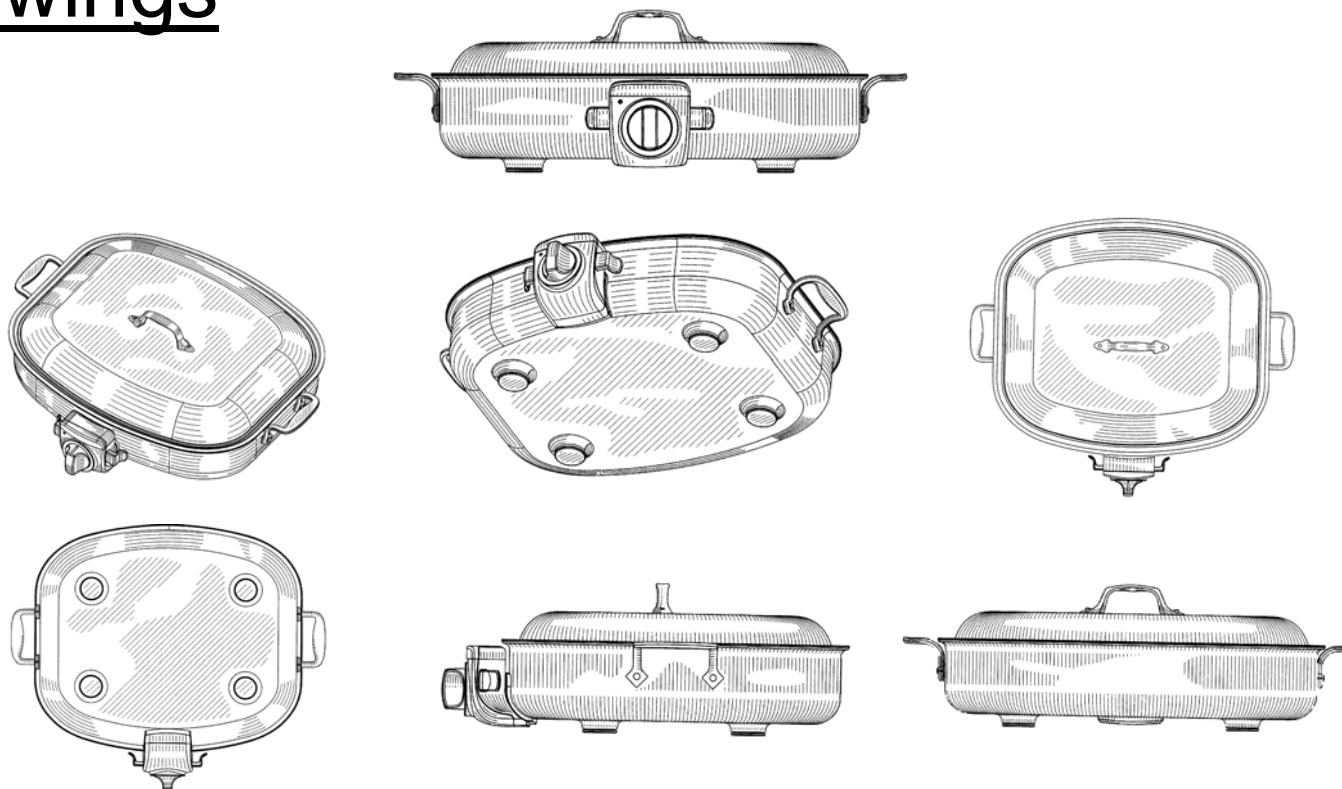

U.S. Design Patent No. 542,592

Infringement

1. Are the patented and accused designs “substantially the same” in the eyes of an ordinary purchaser?

“[I]f, in the eye of an ordinary observer, giving such attention as a purchaser usually gives, two designs are substantially the same, if the resemblance is such as to deceive an ordinary observer, inducing him to purchase one supposing it to be the other, the first one patented is infringed by the other.”

Gorham v. White, 81 U.S. (14 Wall) 511 (1871).

Guidelines for Application of Gorham Test:

- Highly subjective test
 - Experts / surveys helpful, but not mandatory
- look at a design as a whole, not individual details
- the proper viewpoint is that of the ordinary observer
- how different is the patented design from pre-existing designs?

Pre-Egyptian Goddess – Additional Prong to Test:

2. Does the accused design “appropriate the novelty in the patented device which distinguishes it from the prior art”?

Litton Systems, Inc. v. Whirlpool Corp., 728 F.2d 1423, 1444 (Fed. Cir. 1984).

Easy case for application of point of novelty test:

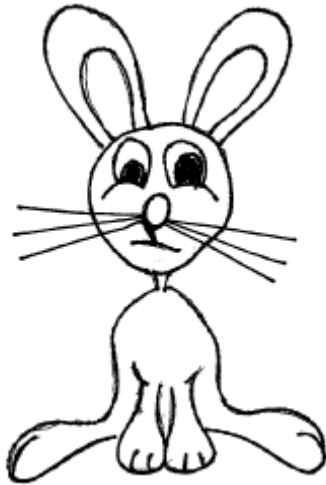

Patented Design

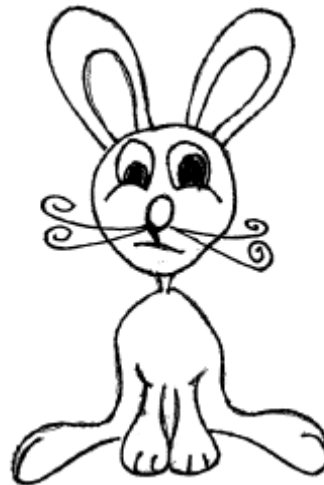

Prior Art Design

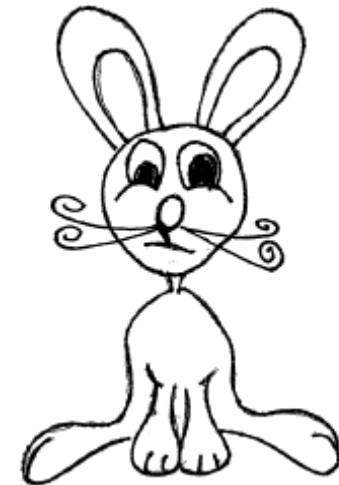

Accused Design

Harder case for applying point of novelty test:

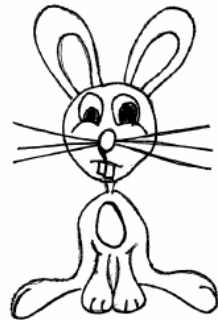

Patented Design

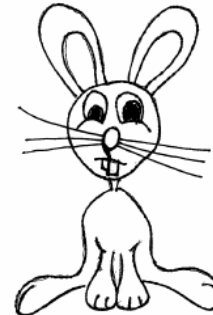

Accused Design

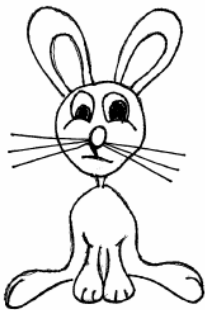

Prior Art Design

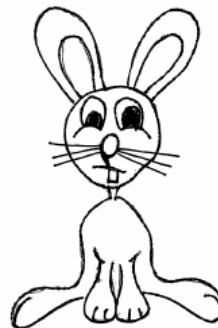

Prior Art Design

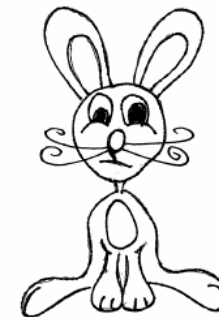

Prior Art Design

Some problems with the point of novelty test:

1. What is a point of novelty? What points of novelty should the analysis focus on?
2. Does the accused design have to appropriate all of the points of novelty, or just some of them?
3. Can a combination of features be a point of novelty by itself?
4. Look at just closest cited art? Un-cited art? Analogous art?

Egyptian Goddess rejects the point of novelty test as a separate and distinct test for infringement:

Now – the *Gorham* ordinary observer test is the sole test for infringement.

However – the ordinary observer test will be informed by the prior art:

“Where there are many examples of similar prior art designs ... differences between the claimed and accused designs that might not be noticeable in the abstract can become significant to the hypothetical ordinary observer who is conversant with the prior art.”

Relatively close prior art means that smaller differences between patented and accused design are important:

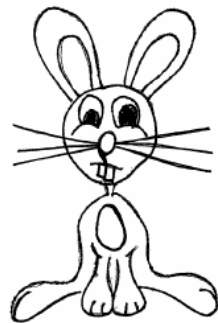

Patented Design

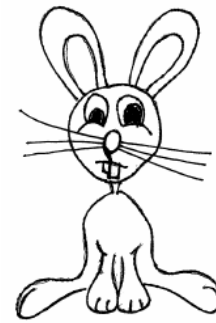

Accused Design

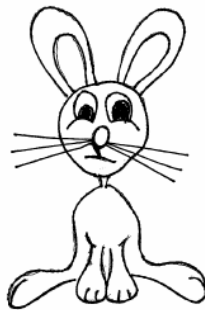

Prior Art

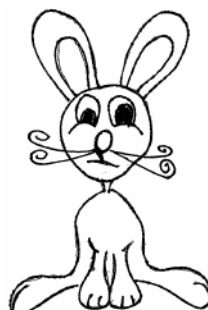

Prior Art

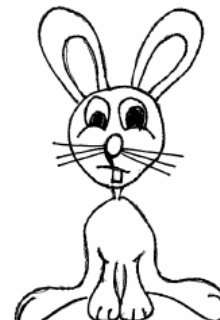

Prior Art

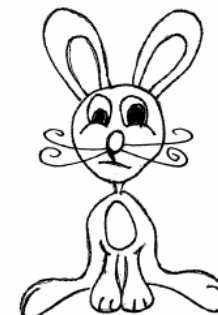

Prior Art

“Less close” prior art means that smaller differences between patented and accused design are less important.

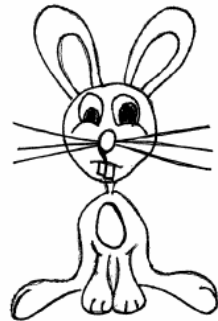

Patented Design

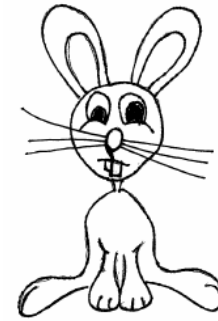

Accused Design



Prior Art Design



Prior Art Design

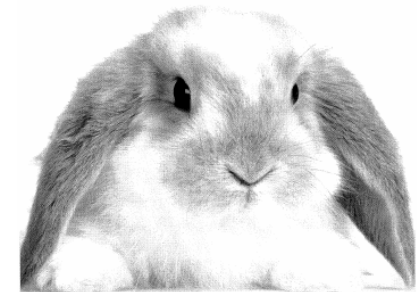

Prior Art Design

Some ways to “broaden” a design patent:

1. Show less detail.
2. Show fewer views.
3. Show more “embodiments.”
4. Use broken lines.
5. Use broken lines “to the extreme.”

Show less detail:

NARROW

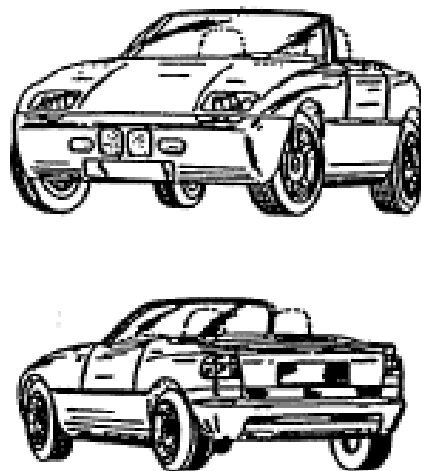

BROADER

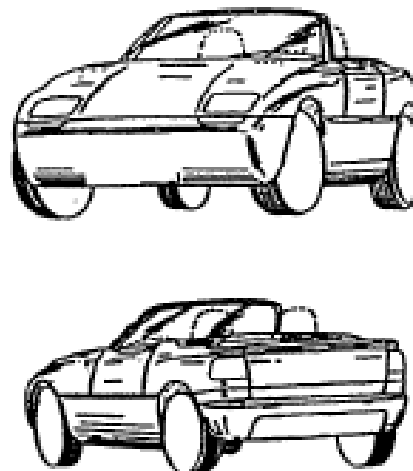

BROADEST

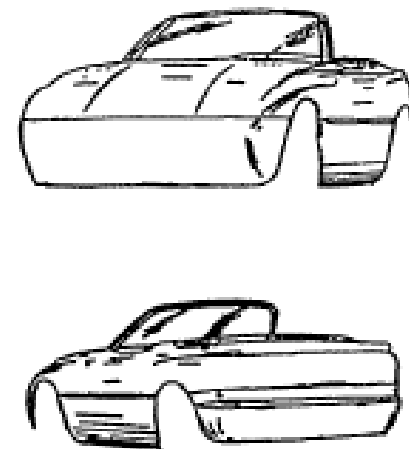

Perry J. Saidman - Design Patentees: Don't Get Unglued By Elmer, JPTOS at p. 332 (May 1996).

Show fewer views:

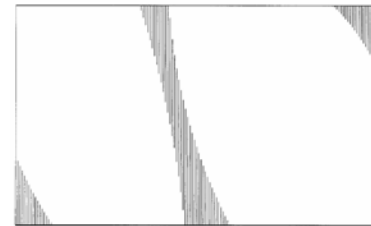
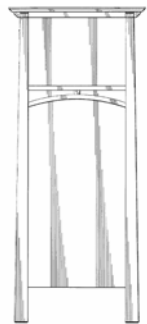
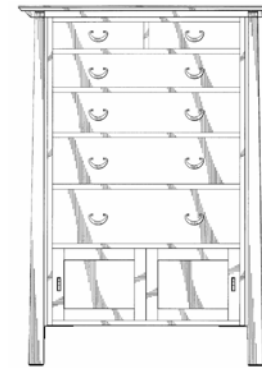
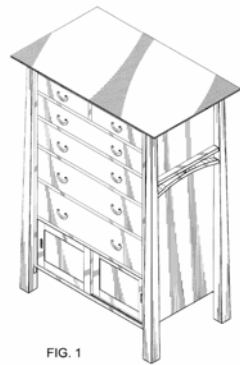

But – watch for “enablement” issues.

Show more “embodiments”:

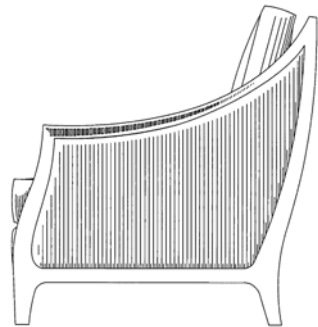

FIG. 1

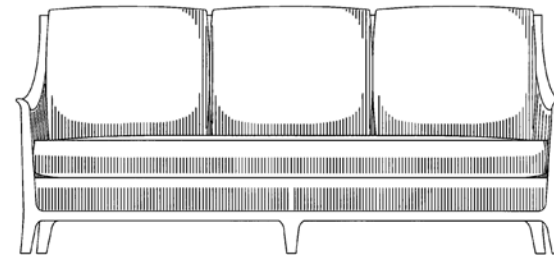

FIG. 2

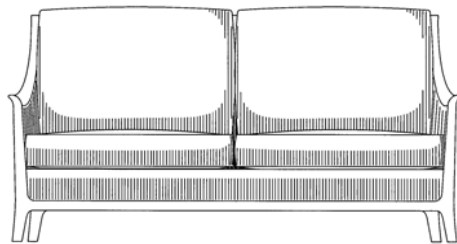

FIG. 4

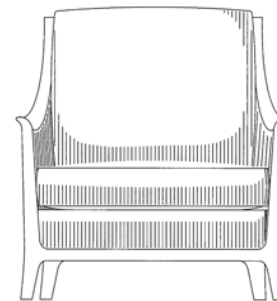
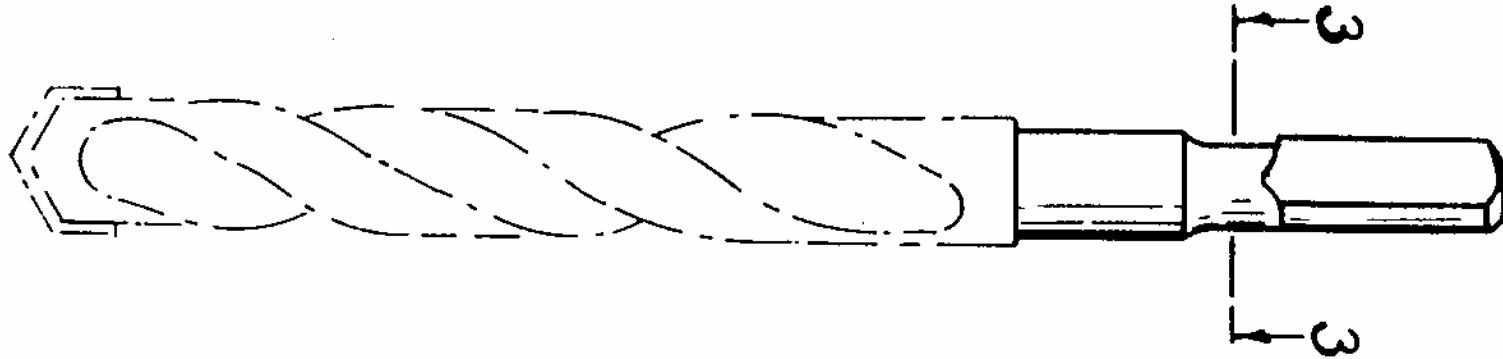

FIG. 6

U.S. Design Patent No. D 560,076

Use broken lines:



In re Zahn, 617 F.2d 261 (CCPA 1980).

Recently, some patentees have tried using broken lines “to the extreme”:

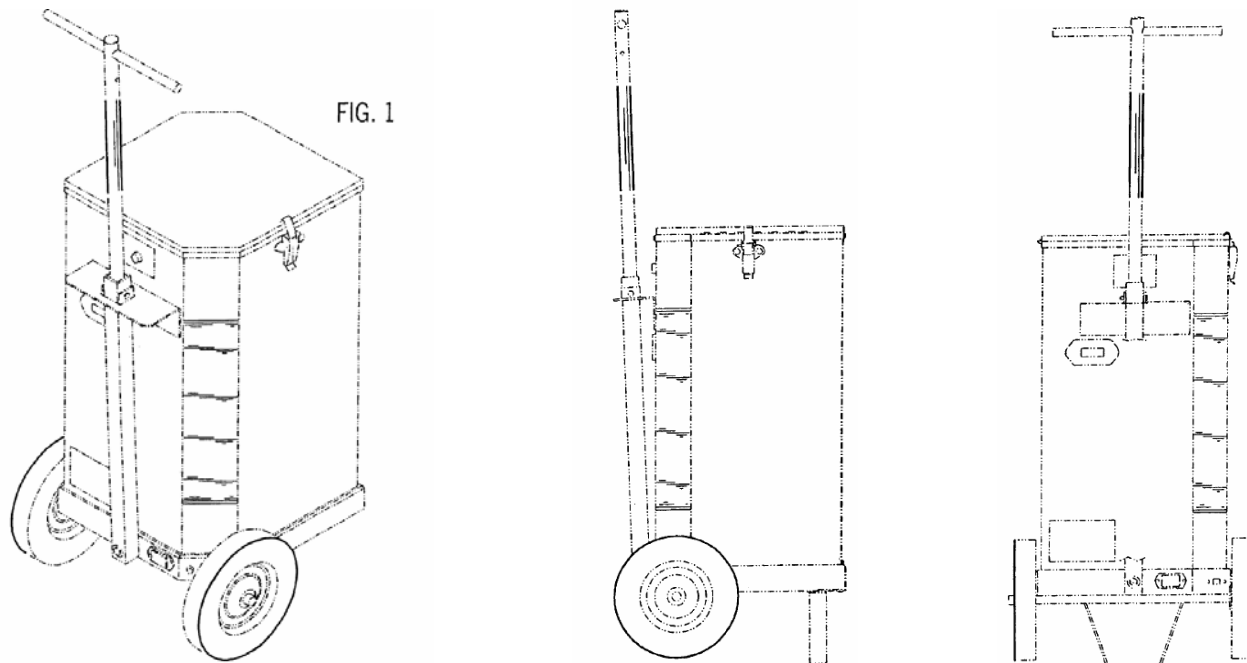

U.S. Design Patent No. 507,928

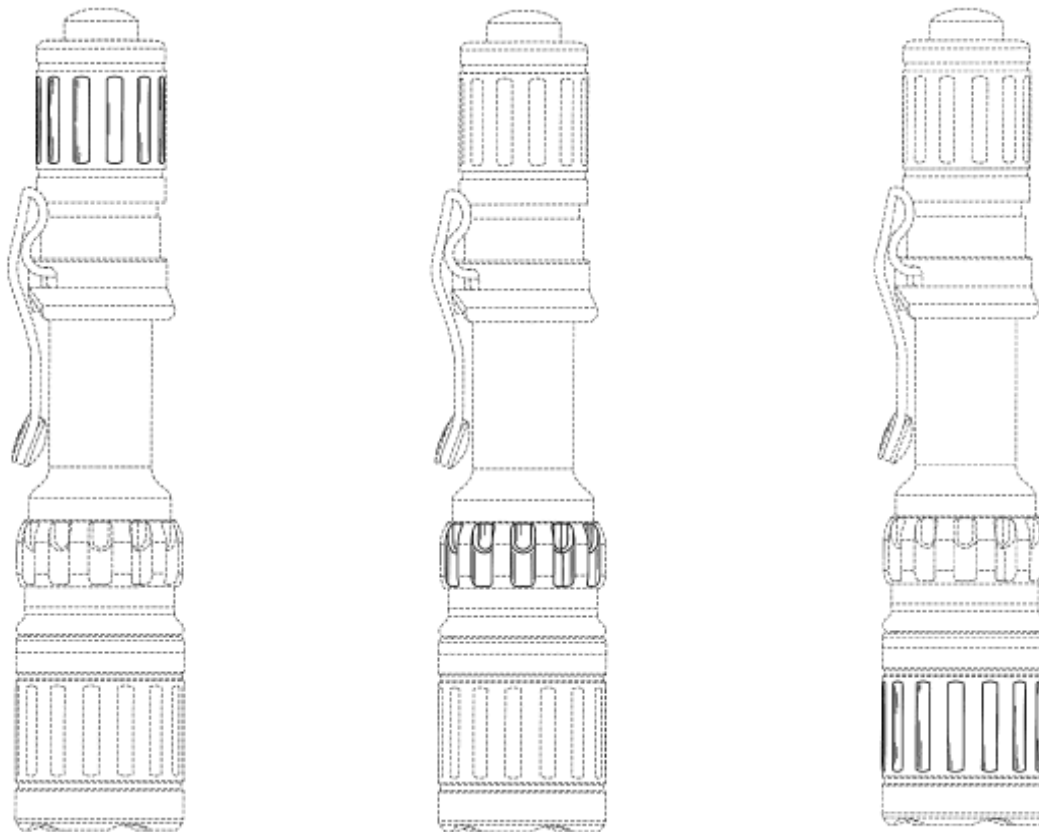

U.S. Design Patent Nos. 578,688, 578,689, 578,690

Benefits of Design Patents

- relatively inexpensive to obtain (about 3K)
exclusive monopoly for 14 years
- relatively straightforward to enforce
- supplement / alternative to trade dress protection
 - no distinctiveness requirement
 - provides 14 years of exclusivity to develop distinctiveness
 - consensus seems to be that design patents and trade dress are not mutually exclusive



Contact Information

Michael Bertelson

t 404 815 6291

MBertelson@KilpatrickStockton.com